

Pump Pompa	Pressure Pressione		Volume Portata				RPM giri/min		Power Potenza			
			l/min		GPM				HP		kW	
	bar	PSI	50 Hz	60 Hz	50 Hz	60 Hz	50 Hz	60 Hz	50 Hz	60 Hz	50 Hz	60 Hz
XLT3020S	200	2900	30	36	7.9	9.5	1000	1200	15.6	18.7	11.5	13.8
XLT3816S	160	2320	38	46	10	12	1000	1200	15.9	19.0	11.7	14.0
XLT1830	300	4350	18	22	4.8	5.8	1450	1740	13.7	16.4	10.1	12.1
XLT2230	300	4350	22	26	5.8	7	1450	1740	16.6	19.9	12.2	14.6
XLT2530	300	4350	25	30	6.6	7.9	1450	1740	19.2	23.0	14.1	16.2
XLT2730	300	4350	27	32	7.1	8.5	1450	1740	20.5	24.6	15.1	18.1
XLT3025	250	3625	30	36	7.9	9.5	1450	1740	19.3	23.2	14.2	17.0
XLT3325	250	3625	33	40	8.7	10.4	1450	1740	21.4	25.7	15.7	18.8
XLT3517	170	2465	35	42	9.2	11	1450	1740	15.2	18.2	11.2	13.4
XLT4017	170	2465	40	48	10.6	12.7	1450	1740	17.0	20.4	12.5	15.0
XLT4317	170	2465	43	52	11.4	13.7	1450	1740	19.1	22.9	14.1	16.9
XLT5015	150	2175	50	60	13.2	15.8	1450	1740	18.8	22.6	13.8	16.6
XLT5415	150	2175	54	65	14.3	17.2	1450	1740	21.2	25.4	15.6	18.7

Dimensioni d'ingombro

Overall dimensions

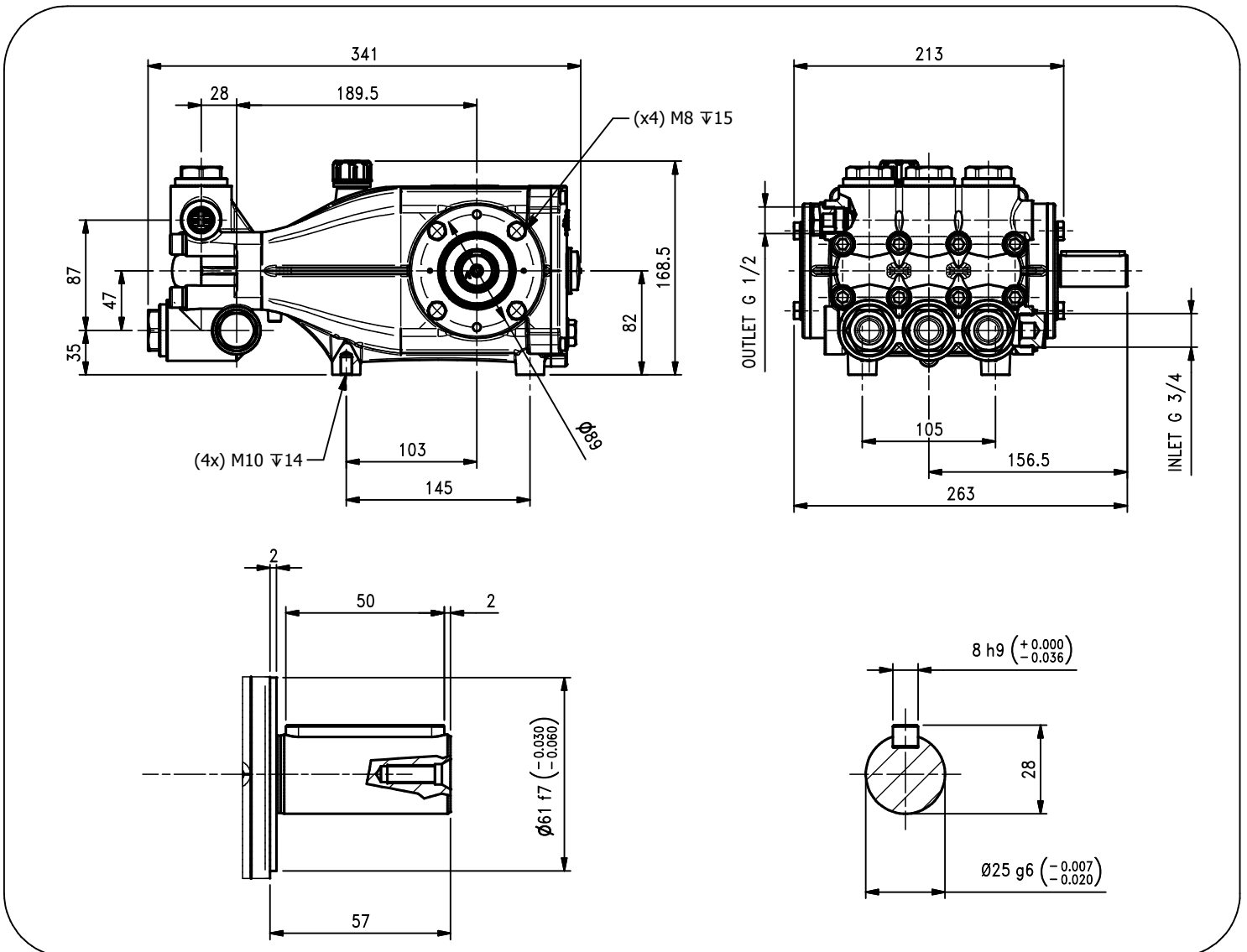

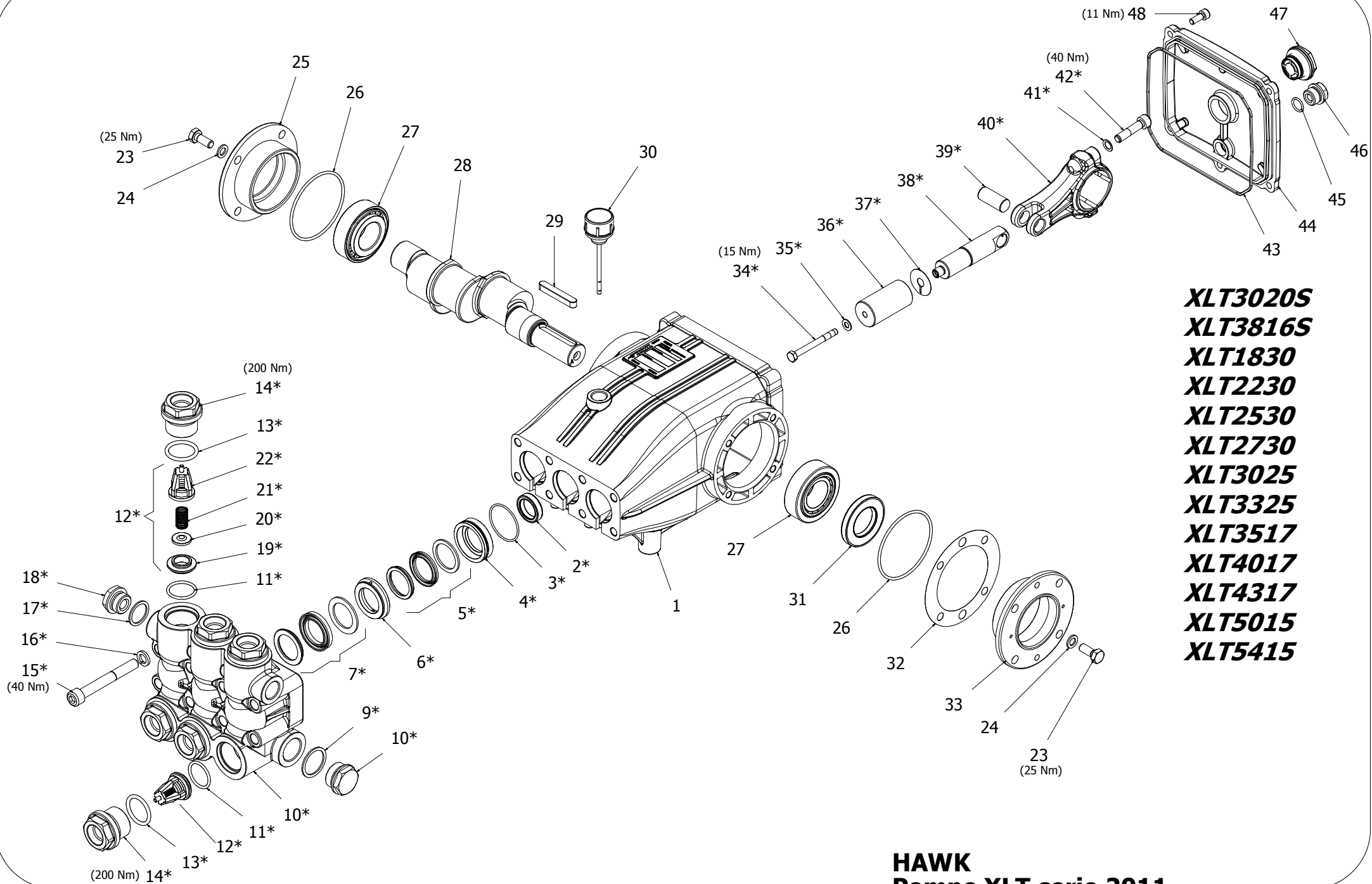

- XLT3020S***
- XLT3816S***
- XLT1830***
- XLT2230***
- XLT2530***
- XLT2730***
- XLT3025***
- XLT3325***
- XLT3517***
- XLT4017***
- XLT4317***
- XLT5015***
- XLT5415***

HAWK
Pompe XLT serie 2011
XLT pumps 2011 series

SPARE PARTS KIT

XLT 2011

Item	Part Number & Description	Q.ty Pump	XL	T30	20	S	XL	T38	16	S	XL	T18	30	XL	T22	30	XL	T25	30	XL	T27	30	XL	T30	25	XL	T33	25	XL	T35	17	XL	T40	17	XL	T43	17	XL	T50	15	XL	T54	15	
3x (3- 5- 7)	2601.26 Plunger Seals 20 mm	1					◆				◆			◆			◆																											
	2601.25 Plunger Seals 22 mm	1																							◆				◆															
	2601.13 Plunger Seals 25 mm	1	◆																														◆				◆							
	2601.15 Plunger Seals 28 mm	1									◆																										◆				◆			
3- 4- 5- 6- 7	2601.28 Complete seal Packing 20 mm	3									◆			◆			◆				◆																							
	2601.27 Complete seal Packing 22 mm	3																							◆				◆															
	2601.14 Complete seal Packing 25 mm	3	◆																														◆				◆							
	2601.16 Complete seal Packing 28 mm	3									◆																										◆				◆			
34- 35- 36- 37	2601.30 Plunger 20 mm	3									◆			◆			◆				◆																							
	2601.29 Plunger 22 mm	3																							◆				◆															
	2601.17 Plunger 25 mm	3	◆																										◆				◆				◆							
	2601.18 Plunger 28 mm	3									◆																										◆				◆			
11- 12- 13	2600.10 Complete Valve	6	◆				◆																						◆				◆				◆				◆			
	2601.31 Complete Valve	6									◆			◆			◆				◆				◆				◆				◆				◆				◆			
3x (2)	2600.03 Plunger oil Seal	1	◆				◆				◆			◆			◆				◆				◆				◆				◆				◆				◆			
3- 4- 5- 6- 7- 8 9- 10- 11- 12 13- 14- 15- 16 17- 18	2601.33 Complete Manifold 20 mm	1									◆			◆			◆				◆																							
	2601.32 Complete Manifold 22 mm	1																							◆				◆															
	2601.19 Complete Manifold 25 mm	1	◆																										◆				◆				◆							
	2601.20 Complete Manifold 28 mm	1									◆																										◆				◆			
38- 39- 40- 41 42	3100.41 Connectin Rod-Plunger Rod Assy	3	◆				◆				◆			◆			◆				◆				◆				◆				◆				◆				◆			

PARTS LIST

XLT 2011

Item	Part Number	Description	Q.ty/Pu mp	XLT3020S	XLT3816S	XLT1830	XLT2290	XLT2530	XLT2730	XLT3025	XLT3325	XLT3517	XLT4017	XLT4317	XLT5015	XLT5415
*1	0202.97	Crankcase	1													
*2	0001.01	Plunger oil seal	3	◆	◆	◆	◆	◆	◆	◆	◆	◆	◆	◆	◆	◆
*3	0601.08	"O" Ring Ø1.78x37.82	3													
*4	1201.57	Pressure ring 20 mm	3			◆	◆	◆	◆							
	1201.59	Pressure ring 22 mm	3							◆	◆					
	1201.58	Pressure ring 25 mm	3	◆								◆	◆	◆		
	1201.56	Pressure ring 28 mm	3		◆										◆	◆
*5	0002.52	"U" seal, dia.20 mm	3			◆	◆	◆	◆							
	0002.53	"U" seal, dia.22 mm	3							◆	◆					
	0002.57	"U" seal, dia.25 mm	3	◆								◆	◆	◆		
	0002.69	"U" seal, dia.28 mm	3		◆										◆	◆
*6	0300.76	Intermed. ring 20mm	3			◆	◆	◆	◆							
	0300.78	Intermed. ring 22mm	3							◆	◆					
	0300.77	Intermed. ring 25mm	3	◆								◆	◆	◆		
	0300.75	Intermed. ring 28mm	3		◆										◆	◆
*7	0002.61	"U" seal, dia.20 mm	3			◆	◆	◆	◆							
	0002.62	"U" seal, dia.22 mm	3							◆	◆					
	0002.72	"U" seal, dia.25 mm	3	◆								◆	◆	◆		
	0002.65	"U" seal, dia.28 mm	3		◆										◆	◆
*8	1601.33	Brass plug G3/4	1	◆	◆	◆	◆	◆	◆	◆	◆	◆	◆	◆	◆	◆
*9	0603.11	Copper washer 3/4	1	◆	◆	◆	◆	◆	◆	◆	◆	◆	◆	◆	◆	◆
*10	1602.39	Manifold housing Ø28/Ø25	1	◆	◆							◆	◆	◆	◆	◆
	1602.40	Manifold housing Ø22/Ø20	1			◆	◆	◆	◆	◆	◆					
*11	0601.66	"O" Ring Ø2.62x25.7	6	◆	◆							◆	◆	◆	◆	◆
	0605.06	"O" Ring Ø2,62x21,89	6			◆	◆	◆	◆	◆	◆					
*12	3604.50	Valve assembly	6	◆	◆							◆	◆	◆	◆	◆
	3604.76	Valve assembly	6			◆	◆	◆	◆	◆	◆					
*13	0601.67	"O" Ring Ø3.53x26.58	6	◆	◆							◆	◆	◆	◆	◆
	0601.87	"O" Ring Ø3,53x25,80-134	6			◆	◆	◆	◆	◆	◆					
*14	1601.31	Valve plug	6	◆	◆							◆	◆	◆	◆	◆
	1601.74	Valve plug	6			◆	◆	◆	◆	◆	◆					
*15	1801.40	Manifold stud bolt	8													
*16	1403.01	Lock-Washer	8	◆	◆	◆	◆	◆	◆	◆	◆	◆	◆	◆	◆	◆
*17	0603.07	Copper washer 1/2	1													
*18	1601.20	Brass plug 1/2	1													
*19	1503.19	Valve seat	6	◆	◆							◆	◆	◆	◆	◆
	1503.40	Valve seat	6			◆	◆	◆	◆	◆	◆					
*20	1202.08	Valve plate	6													
*21	0900.32	Valve spring	6													
*22	0604.06	Valve cage	6													
23	1802.05	Hexagonal screw	8	◆	◆	◆	◆	◆	◆	◆	◆	◆	◆	◆	◆	◆
24	1400.01	Washer	8													
25	0500.54	Closed bearing housing	1													
26	0601.00	"O" Ring Ø2.62x71.12	2													
27	0200.04	Roller bearing	2													
28	0006.35	Crankshaft Ø25	1			◆										
	0006.33	Crankshaft Ø25	1				◆					◆				
	0006.34	Crankshaft Ø25	1					◆		◆			◆		◆	
	0006.26	Crankshaft Ø25	1	◆	◆				◆		◆			◆		◆

XLT 2011

PARTS LIST

Item	Part Number	Description	Q.ty/Pu mp	XLT3020S	XLT3816S	XLT1830	XLT2230	XLT2530	XLT2730	XLT3025	XLT3325	XLT3517	XLT4017	XLT4317	XLT5015	XLT5415
29	0206.05	Crankshaft key	1													
30	1600.16	Oil dip stick	1													
31	0001.00	Crankshaft seal	1													
32	0301.00	Shim	1	◆	◆	◆	◆	◆	◆	◆	◆	◆	◆	◆	◆	◆
33	0500.53	Bearing housing	1													
*34	1802.23	Plunger bolt	3													
*35	1400.10	Copper spacer	3													
*36	1200.32	Plunger 20 mm	3			◆	◆	◆	◆							
	1200.34	Plunger 22 mm	3							◆	◆					
	1200.33	Plunger 25 mm	3	◆								◆	◆	◆		
	1200.30	Plunger 28 mm	3		◆										◆	◆
*37	1400.57	Copper spacer	3													
*38	0003.32	Plunger rod	3													
*39	1502.07	Connecting rod pin	3													
*40	0100.10	Connecting rod	3													
*41	1401.03	Spring washer	6													
42	1801.01	Connecting rod screw	6	◆	◆	◆	◆	◆	◆	◆	◆	◆	◆	◆	◆	◆
43	0601.85	"O" Ring Ø2,62x152,07	1													
44	0203.60	Crankcase cover	1													
45	0601.14	"O" Ring Ø1,78x14,00	1													
46	1601.17	Brass plug 3/8	1													
47	0700.05	Sight glass, G3/4	1													
48	1801.41	Cover screw	5													

* Part available
in kit only

* Part available
in kit also

Posizioni	Codice e Descrizione	Q.tà Pompa	XLT3020S	XLT3816S	XLT1830	XLT2230	XLT2530	XLT2730	XLT3025	XLT3325	XLT3517	XLT4017	XLT4317	XLT5015	XLT5415
3x (3- 5- 7)	2601.26 <i>Guarnizioni pistone Ø20</i>	1			◆	◆	◆	◆							
	2601.25 <i>Guarnizioni pistone Ø22</i>	1							◆	◆					
	2601.13 <i>Guarnizioni pistone Ø25</i>	1	◆								◆	◆	◆		
	2601.15 <i>Guarnizioni pistone Ø28</i>	1		◆										◆	◆
3- 4- 5- 6- 7	2601.28 <i>Pacco completo Guarnizioni pistone Ø20</i>	3			◆	◆	◆	◆							
	2601.27 <i>Pacco completo Guarnizioni pistone Ø22</i>	3							◆	◆					
	2601.14 <i>Pacco completo Guarnizioni pistone Ø25</i>	3	◆								◆	◆	◆		
	2601.16 <i>Pacco completo Guarnizioni pistone Ø28</i>	3		◆										◆	◆
34- 35- 36- 37	2601.30 <i>Pistone Ø20</i>	3			◆	◆	◆	◆							
	2601.29 <i>Pistone Ø22</i>	3							◆	◆					
	2601.17 <i>Pistone Ø25</i>	3	◆								◆	◆	◆		
	2601.18 <i>Pistone Ø28</i>	3		◆										◆	◆
11- 12- 13	2600.10 <i>Valvola completa</i>	6	◆	◆							◆	◆	◆	◆	◆
	2601.31 <i>Valvola completa</i>	6			◆	◆	◆	◆	◆	◆					
3x (2)	2600.03 <i>Anelli tenuta olio Asta</i>	1	◆	◆	◆	◆	◆	◆	◆	◆	◆	◆	◆	◆	◆
3- 4- 5- 6- 7- 8 9- 10- 11- 12 13- 14- 15- 16 17- 18	2601.33 <i>Testata Completa Ø20</i>	1			◆	◆	◆	◆							
	2601.32 <i>Testata Completa Ø22</i>	1							◆	◆					
	2601.19 <i>Testata Completa Ø25</i>	1	◆								◆	◆	◆		
	2601.20 <i>Testata Completa Ø28</i>	1		◆										◆	◆
38- 39- 40- 41 42	3100.41 <i>Premontato asta-biella</i>	3	◆	◆	◆	◆	◆	◆	◆	◆	◆	◆	◆	◆	◆

Pos.	Codice	Descrizione	Q.tà/Po mpa	XLT3020S	XLT3816S	XLT1830	XLT2290	XLT2530	XLT2730	XLT3025	XLT3325	XLT3517	XLT4017	XLT4317	XLT5015	XLT5415
*1	0202.97	Carter	1													
*2	0001.01	Anello radiale	3	◆	◆	◆	◆	◆	◆	◆	◆	◆	◆	◆	◆	◆
*3	0601.08	"O" Ring Ø1.78x37.82	3													
*4	1201.57	Pressore Ø20	3			◆	◆	◆	◆							
	1201.59	Pressore Ø22	3							◆	◆					
	1201.58	Pressore Ø25	3	◆								◆	◆	◆		
	1201.56	Pressore Ø28	3		◆										◆	◆
*5	0002.52	Anello tenuta "U" Ø20	3			◆	◆	◆	◆							
	0002.53	Anello tenuta "U" Ø22	3							◆	◆					
	0002.57	Anello tenuta "U" Ø25	3	◆								◆	◆	◆		
	0002.69	Anello tenuta "U" Ø28	3		◆										◆	◆
*6	0300.76	Diffusore interm. Ø20	3			◆	◆	◆	◆							
	0300.78	Diffusore interm. Ø22	3							◆	◆					
	0300.77	Diffusore interm. Ø25	3	◆								◆	◆	◆		
	0300.75	Diffusore interm. Ø28	3		◆										◆	◆
*7	0002.61	Anello tenuta "U" Ø25	3			◆	◆	◆	◆							
	0002.62	Anello tenuta "U" Ø25	3							◆	◆					
	0002.72	Anello tenuta "U" Ø25	3	◆								◆	◆	◆		
	0002.65	Anello tenuta "U" Ø28	3		◆										◆	◆
*8	1601.33	Tappo G3/4	1	◆	◆	◆	◆	◆	◆	◆	◆	◆	◆	◆	◆	◆
*9	0603.11	Guarnizione rame G3/4	1	◆	◆	◆	◆	◆	◆	◆	◆	◆	◆	◆	◆	◆
*10	1602.39	Testata Ø28/Ø25	1	◆	◆							◆	◆	◆	◆	◆
	1602.40	Testata Ø22/Ø20	1			◆	◆	◆	◆	◆	◆					
*11	0601.66	"O" Ring Ø2,62x25,07	6	◆	◆							◆	◆	◆	◆	◆
	0605.06	"O" Ring Ø2,62x21,89	6			◆	◆	◆	◆	◆	◆					
*12	3604.50	Valvola premontata	6	◆	◆							◆	◆	◆	◆	◆
	3604.76	Valvola premontata	6			◆	◆	◆	◆	◆	◆					
*13	0601.67	"O" Ring Ø3.53x26.58	6	◆	◆							◆	◆	◆	◆	◆
	0601.87	"O" Ring Ø3,53x25,80	6			◆	◆	◆	◆	◆	◆					
*14	1601.31	Tappo valvola	6	◆	◆							◆	◆	◆	◆	◆
	1601.74	Tappo valvola	6			◆	◆	◆	◆	◆	◆					
*15	1801.40	Vite M10x80	8													
*16	1403.01	Rosetta elastica Ø10,2	8	◆	◆	◆	◆	◆	◆	◆	◆	◆	◆	◆	◆	◆
*17	0603.07	Guarnizione rame G1/2	1													
*18	1601.20	Tappo G1/2	1													
*19	1503.19	Sede valvola	6	◆	◆							◆	◆	◆	◆	◆
	1503.40	Sede valvola	6			◆	◆	◆	◆	◆	◆					
*20	1202.08	Piattello valvola	6													
*21	0900.32	Molla valvola	6													
*22	0604.06	Gabbia valvola	6													
23	1802.05	Vite M8x20	8	◆	◆	◆	◆	◆	◆	◆	◆	◆	◆	◆	◆	◆
24	1400.01	Rosetta Ø8.5	8													
25	0500.54	Flangia chiusa	1													
26	0601.00	"O" Ring Ø2.62x71.12	2													
27	0200.04	Cuscinetto a rulli	2													
28	0006.35	Albero eccentrico Ø25	1			◆										
	0006.33	Albero eccentrico Ø25	1				◆				◆					
	0006.34	Albero eccentrico Ø25	1					◆		◆		◆			◆	
	0006.26	Albero eccentrico Ø25	1	◆	◆				◆		◆			◆		◆

LISTA PARTI

XLT 2011

Pos.	Codice	Descrizione	Q.tà/Po mpa	XLT3020S	XLT3816S	XLT1830	XLT2230	XLT2530	XLT2730	XLT3025	XLT3325	XLT3517	XLT4017	XLT4317	XLT5015	XLT5415
29	0206.05	Chiavetta	1													
30	1600.16	Tappo livello olio	1													
31	0001.00	Anello radiale	1													
32	0301.00	Distanziale	1	◆	◆	◆	◆	◆	◆	◆	◆	◆	◆	◆	◆	◆
33	0500.53	Flangia aperta	1													
*34	1802.23	Vite pistone	3													
*35	1400.10	Rosetta rame	3													
*36	1200.32	Pistone Ø20	3			◆	◆	◆	◆							
	1200.34	Pistone Ø25	3							◆	◆					
	1200.33	Pistone Ø25	3	◆								◆	◆	◆		
	1200.30	Pistone Ø28	3		◆										◆	◆
*37	1400.57	Rosetta rame	3													
*38	0003.32	Asta pistone	3													
*39	1502.07	Spinotto	3													
*40	0100.10	Biella completa	3													
*41	1401.03	Rosetta elastica Ø8	6													
42	1801.01	Vite M8x35	6	◆	◆	◆	◆	◆	◆	◆	◆	◆	◆	◆	◆	◆
43	0601.85	"O" Ring Ø2,62x152,07	1													
44	0203.60	Coperchio	1													
45	0601.14	"O" Ring Ø1,78x14,00	1													
46	1601.17	Tappo G3/8	1													
47	0700.05	Spia livello olio G3/4	1													
48	1801.41	Vite M6x20	5													

* Particolare disponibile
solo in kit

* Particolare disponibile
anche in kit